

USER'S MANUAL



CMD Series

CMD 160D

CMD 160A

CMD 210A



























HALF METAL CEILING FAN

Thank you for choosing half metal ceiling mounted fan. Please read and save this user's manual for future reference. Read carefully before attempting to assemble, install, operate or maintain the product described. Protect yourself and others by observing all safety information. Failure to comply with instructions could result in personal injury and property damage.

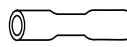
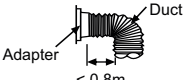

1. GENERAL SAFETY INFORMATION

- Please read the user's manual carefully prior to installing and operating the unit.
- This user's manual is the primary operating document intended for technical, maintenance and operations staff.
- All user's manual requirements as well as the provisions of all the applicable local and national construction, electrical and technical norms and standards must be observed when installing and operating the unit.
- The warnings contained in the user's manual must be considered most seriously since they contain vital personal safety information.
- Failure to follow the rules and safety precautions noted in this user's manual may result in an injury or unit damage. After a careful reading of the manual, keep it for the entire service life of the unit.
- While transferring the unit control, the user's manual must be turned over to the receiving operator.

 UNIT INSTALLATION AND OPERATION SAFETY PRECAUTIONS			
	Disconnect the unit from power mains prior to any installation operations.		Unpack the unit with care.
	The unit must be grounded!		While installing the unit, follow the safety regulations specific to the use of electric tools.
	Do not change the power cable length at your own discretion. Do not bend the power cable. Avoid damaging the power cable. Do not put any foreign objects on the power cable.		Do not lay the power cable of the unit in close proximity to heating equipment.
	Do not use damaged equipment or cables when connecting the unit to power mains.		Do not operate the unit outside the temperature range stated in the user's manual. Do not operate the unit in aggressive or explosive environments.
	Do not touch the unit controls with wet hands. Do not carry out the installation and maintenance operations with wet hands.		Do not wash the unit with water. Protect the electric parts of the unit against ingress of water.
	Do not allow children to operate the unit.		Disconnect the unit from power mains prior to any technical maintenance.
	Do not store any explosive or highly flammable substances in close proximity to the unit.		When the unit generates unusual sounds, odour or emits smoke, disconnect it from power supply and contact the Seller.
	Do not open the unit during operation.		Do not direct the air flow produced by the unit towards open flame or ignition sources.
	Do not block the air duct when the unit is switched on.		In case of continuous operation of the unit, periodically check the security of mounting.
	<ul style="list-style-type: none"> • Before installing this product, ensure that the voltage and frequency consistent with the product nameplate. • When connected to power supply, all-pole power switch with more than 3mm contact separation is necessary to be installed on the power supply circuit. Please do the connection according to the local electrical equipment technical regulations. • Please set up vent and spot inspection. • Installation height should be more than 2.3m. • Should be firmly installed. Gradient installation forbidden. 		<ul style="list-style-type: none"> • Do not disassemble the junction box by yourself, if the power cord is damaged, it should repair by qualified serviceman • Installation on window or outdoor is forbidden. • Places with overmuch lampblack or steam forbidden. • Below connection way of air duct is forbidden. <div style="display: flex; justify-content: space-around; align-items: flex-end;"> <div style="text-align: center;">  <p>Multiple bend</p> </div> <div style="text-align: center;">  <p>Pipe diameter shrinks at connecting part</p> </div> <div style="text-align: center;">  <p>Adapter Duct < 0.8m Outlet closed to crook</p> </div> </div>
	<p>The product must be disposed separately at the end of its service life. Do not dispose the unit as unsorted municipal waste.</p>		

2. PRODUCTS OVERVIEW

The CMD series is designed luxury ceiling exhaust fan which use as ducted and unducted ceiling mounted extractions.

The CMD series are offered with motor types:

- CMD-A series: AC motor.
- CMD-D series: DC motor.

Material:

- Casing: Half metal and powder coated.
- Impeller: ABS polymer and high efficiency forward curve centrifugal impeller driven with sealed for by long life bearing.
- Motor: 100% copper coil and fitted with high quality ball bearing, high efficiency, low noise, maintenance free and long service life. Equipped with thermal overload protection.
- Standard motor range is protected to IP 44, class B insulation.

Feature:

- Be able to speed controllable.
- Low noise levels, including valve one-way

Application: Shopping malls, entertainment and residential area, bathroom, bedroom, office, living room, store, toilets, hotels and exhaust ventilation.

Construction.

The half metal ceiling mounted fan consists of the following main parts:

- | | |
|---------------------------|--------------------------|
| 1. Half Metal Casing | 6. Terminal Electric Box |
| 2. Motor Frame | 7. Louver |
| 3. Centrifugal Casing | 8. Valve One-Way |
| 4. Forward Curve Impeller | 9. Outlet Duct |
| 5. Screws | |

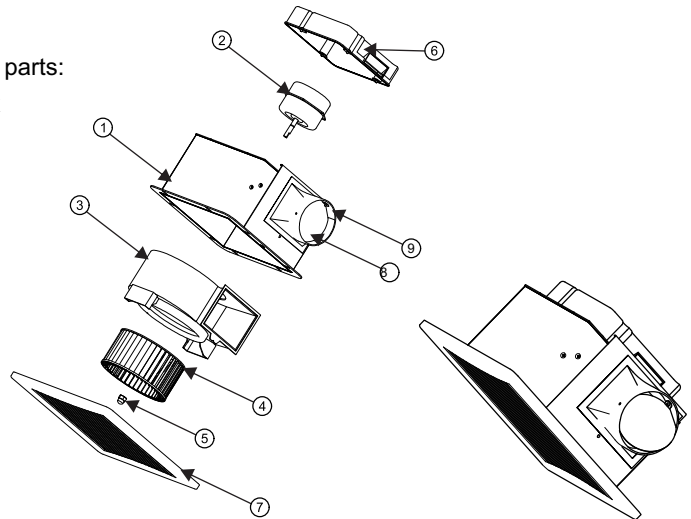

Half metal ceiling mounted fan with standard motor are suitable for ventilation of:

- Clean air
- Slightly dusty and greasy air
- Slightly aggressive gases and vapour
- Mediums up to an atmospheric density of 1.2 kg/m³
- Mediums with a temperature of -20°C up to +40°C
- Mediums up to a max. Humidity of 85%
- The ambient temperature of the motor must be between -20°C and +40°C make sure and adhere to the specifications of the motor manufacturer.

3. PERFORMANCE CURVE

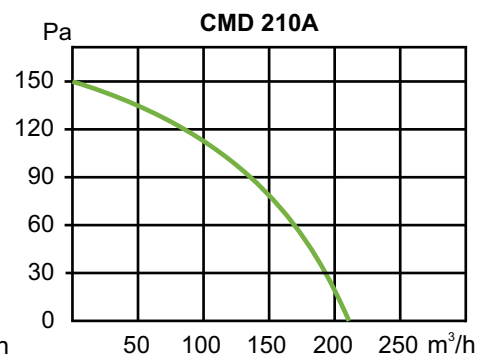
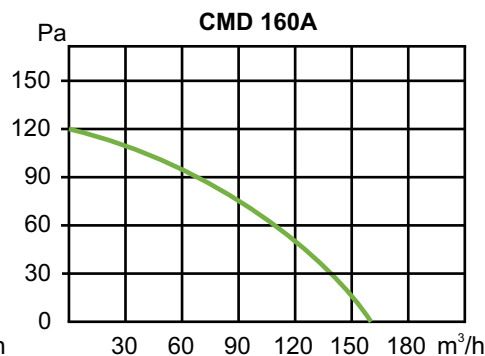
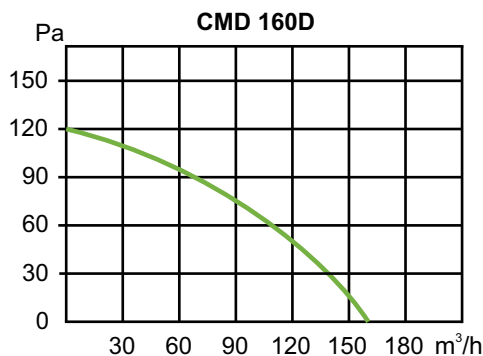

4. PERFORMANCE PARAMETERS

Model	Max. Air Volume (m ³ /h)	Max. Pressure (Pa)	Power (W)	Speed (rpm/min)	Voltage (V/P/Hz)	Noise dBA (at 3m)	Installation (mm)	Weight (Kg)
CMD 160D	160	120	6	900	220/1/50	28	240x240	4.0
CMD 160A	160	120	22	1020	220/1/50	29	210X210	3.0
CMD 210A	210	150	30	1020	220/1/50	33	240X240	3.5

5. DIMENSION INFORMATION

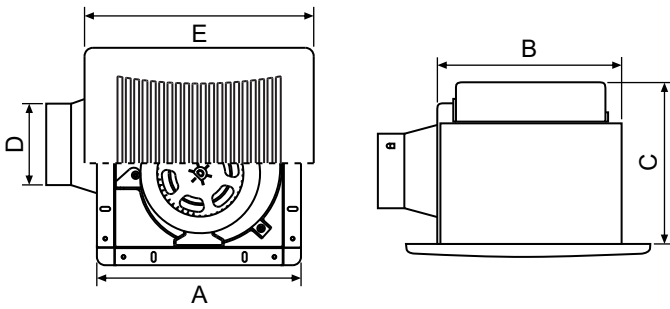

Model	A	B	C	D	E
CMD 160D	270	230	185	100	300
CMD 160A	245	205	185	100	275
CMD 210A	270	230	185	100	300

All dimensions in mm.

6. ELECTRIC INSTALLATION

Electric Connection

- The fan is designed for 220-240V/50Hz (single-phase).
- The fan shall be connected to power supply by means of insulated, durable and thermal-resistant cords (cables, wires).
- Electric wiring must be in accordance with technical connection regulations and local ordinances and national electric codes as per enclosed wiring diagram in the terminal box or on the casing.
- The recommended wire cross section is minimum 0.75 mm².
- The actual conductor cross-section selection must be based on its type, maximum permissible heating, insulation, length and installation method (in the air, pipes or inside walls). Connect the cables to the terminal block incorporated inside the terminal box located on the fan casing in compliance with the fan wiring diagram and the terminal designation. The terminal designations are shown on the sticker inside the fan casing.
- Check that supply is according to data on nameplate.
- Insert cable according to the instructions in the junction box and seal it (Avoid water enter). The equipment connected ground for motor protection according to the instructions - Unless the guarantee isn't accepted. Connect electric supply.
- After connecting the wiring, install the terminal cover with screws.

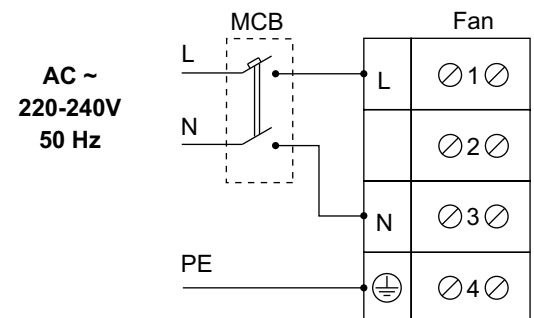

Wiring Diagram

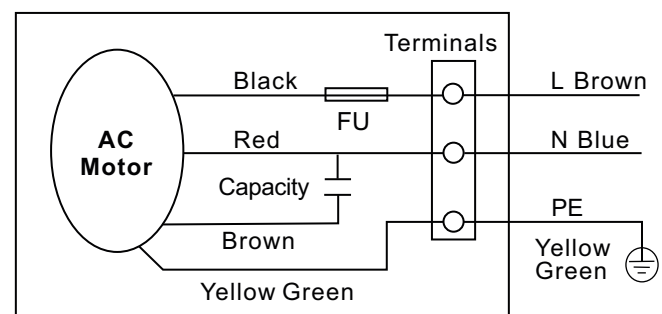
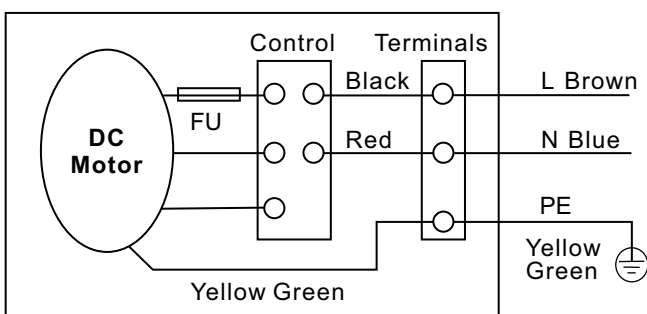

7. INSTALLATION METHOD

- Make a wooden frame and fix it on to the ceiling as picture reference.
- Install and enclose the fan casing in the wooden frame, and then fix it up firmly with 04 self-tapping screws.
- Connect the pipeline with the main part, and make it well-sealed with the self-adhesive tape (bandage). (Fix the ventilating pipeline onto the ceiling, keeping the ventilating pipeline straight, without burden on the main part) no burden on the pipeline.
- After connecting the power supply, turn on the switch, check whether there is abnormal condition, and then place spring in the slot hole to fix the panel.
- We must prevent the gas from the open airway or other firing equipment from back flowing into the room.

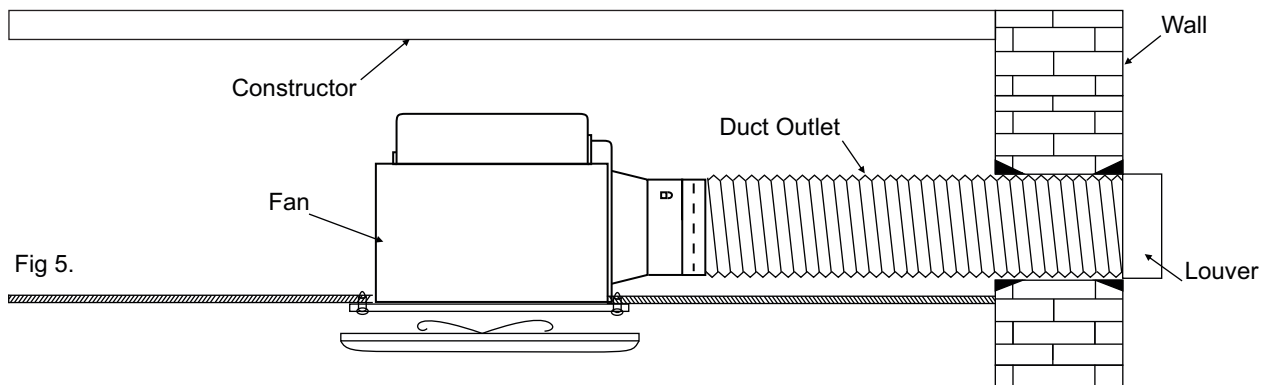
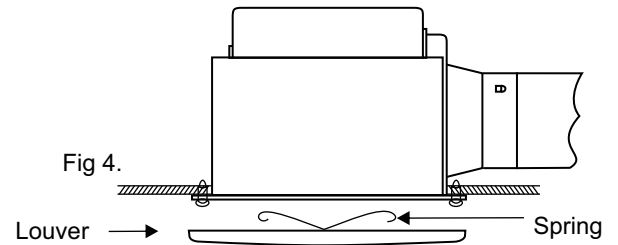
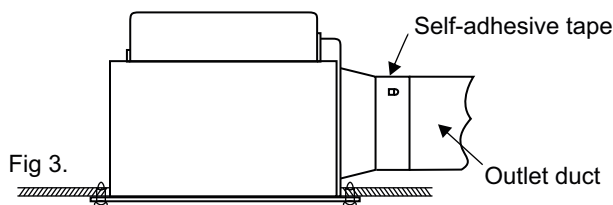
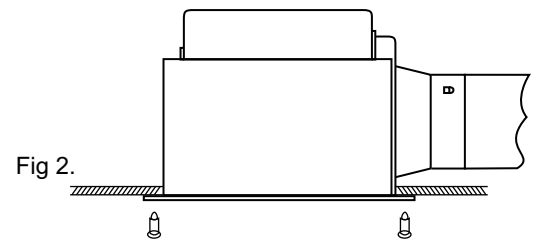
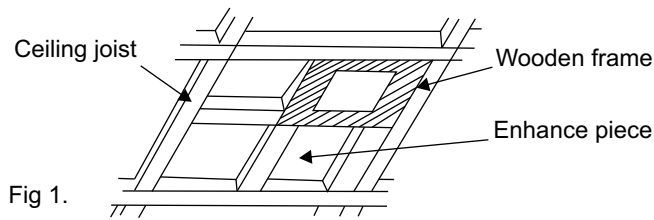

8. OPERATION INSTRUCTION

Visual Inspection of Equipment

- The equipment type and arrangement should be verified as ordered at once when it arrives at the jobsite. When a discrepancy is found, the local Breeze Sales Representative must be notified immediately so that corrective action may be investigated, also verify electrical conformance to specifications. Unauthorized alterations and unauthorized backcharges will not be recognized by Breeze Fan.
- After the unit has been assembled, installed and all utilities have been hooked up, the unit is now ready for operation.

Check

Before starting the unit, check the following:

- Confirm that building supply voltage matches the voltage for which the unit is wired.
- Check all piping and wiring penetrations
- Made by contractors for water tightness. All penetrations must be made watertight to prevent water damage to the unit and building.
- Rotate the fan impeller manually to be sure that it is free to operate. Remove any dirt or debris that may have accumulated during installation.
- Inspect all fasteners to ensure that none have loosened during shipment.
- Check all electrical connections for proper attachment.
- Check casing and ductwork, if accessible, for obstructions and foreign material that may damage the fan impeller.

Checks prior to initial start-up

Proceed with the fan's initial start-up in the following sequence:

- Check that the mechanical assembly has been carried out properly
- Remove foreign bodies located in the suction and outflow areas and in the fan space
- Check that the electrical installation has been completed in accordance with regulations
- Does the mains voltage match the motor voltage specified on the rating plate?
- Is the motor protection system set correctly with regard to the motor's nominal current? The setting must be carried out in accordance with the corresponding details contained on the motor output plate.
- Has the motor been connected correctly in accordance with the wiring diagram? The connection schematic supplied by the motor suppliers applies for the connection of the motor.

Starting up the fan for the first time.

Only put the fan into operation after it has been assembled in accordance with the regulations:

- Put the fan into operation.
- Monitor its correct function (quiet running, vibration, imbalance, power consumption, controllability)

Once the unit has been put into operation, a routine maintenance schedule should be set up to accomplish the following:

- Lubrication of bearings and motor.
- Impeller, casing, bolts and set screws on the entire fan should be checked for tightness.
- Any dirt accumulation on the impeller or in the casing should be removed to prevent unbalance and possible damage.
- Inspect fan impeller and casing looking for fatigue, corrosion or wear.

Checks after initial start-up

Check the mechanical connections after initial start-up, especially the joints at the fan.

9. ROUTINE MAINTENANCE

- Regular maintenance is needed each year. The impeller blades require thorough cleaning once in 6 months.
- Before any maintenance work is undertaken:
 - Stop fan in accordance to regulations and disconnect all poles from mains supply.
 - Wait until impeller is stationary.
 - Make sure that a restart is not possible
- Use only original spare parts tested and approved by the manufacturer.
- The following safety notes must be observed when maintaining the machine.
- Replace the ball bearings of the motor whenever the grease utilization period has elapsed in accordance with the maintenance instructions of the manufacturer.
- The technical maintenance includes periodic cleaning of the surfaces from accumulated dust and dirt.
- Use a soft dry brush or a vacuum cleaner to remove dust.
- Only use usual commercial cleaning material paying attention to the prescribed safety measures and do not use any abrasive tools (surface protection will be destroyed)..

Prior to all servicing work:

- Bring the fan to a halt in the prescribed manner and completely isolate the fan from the mains supply.
- Wait until the rotor has come to a halt.
- Ensure that the machine cannot be switched on again
- Clean the fan
- Clean the suction apertures
- Clean the rotor (if necessary dismantle the protective anti-intrusion fitting)
- Do not overload the motor.

General Check:

- Too much bearing play?
- Lubricant leaking from the bearings?
- Surface protective coating damaged?
- Attention: Conveyed medium too aggressive?
- Unusual noises during operation?
- Fan output still sufficient for possibly extended or shortened ducting system?

Clean fan:

- Remove louver, orifice and impeller.
- Remove the fan casing in the wooden frame.
- Clean dirt on fan casing. Wash and clean louver, orifice.
- Clean impeller.
 - Do not flood motor.
 - Do not bend impeller, blades.
- Using a cloth dampened with kitchen detergent, remove any dirt from fan body, wipe dry with new cloth.
- Assembly fan.
- Control whether installation is correct:
 - Motor impeller must rotate free
 - The gap between impeller and casing must be regular.
 - Checking direction of rotation is correct.
- Install the fan into air duct.
- Connect electric supply of motor.

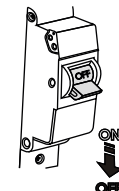

Fig 1

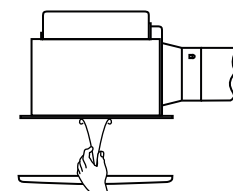

Fig 2

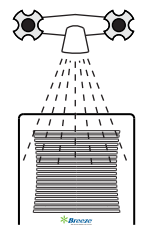

Fig 3

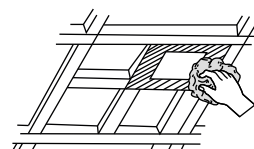

Fig 4

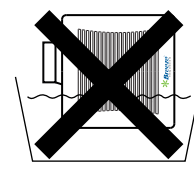

Fig 5

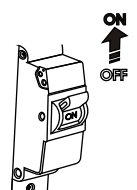

Fig 6

10. REPAIR

Before any repairs are undertaken please:

- Stop fan in accordance to regulations and disconnect all poles from mains supply.
- Wait until impeller is stationary.
- Make sure that a restart is not possible.
- Only use original spare parts manufactured and supplied by Breeze Fan.

Change of motor impeller:

- Disconnect electrical supply in function box.
- Remove louver.
- Remove the fan casing in the wooden frame.
- Unscrews and remove centrifugal casing and impeller.
- Unscrews motor mounting and replace new motor.
- Assembly fan.
- Control whether installation is correct:
 - Motor and impeller must rotate freely
 - Control whether direction of rotation is correct.
 - Install maintenance cover if have.
 - The gap between impeller and casing must be regular.
- Install the fan into air duct.
- Push into operation after repaired.
- Connect electric supply of motor.

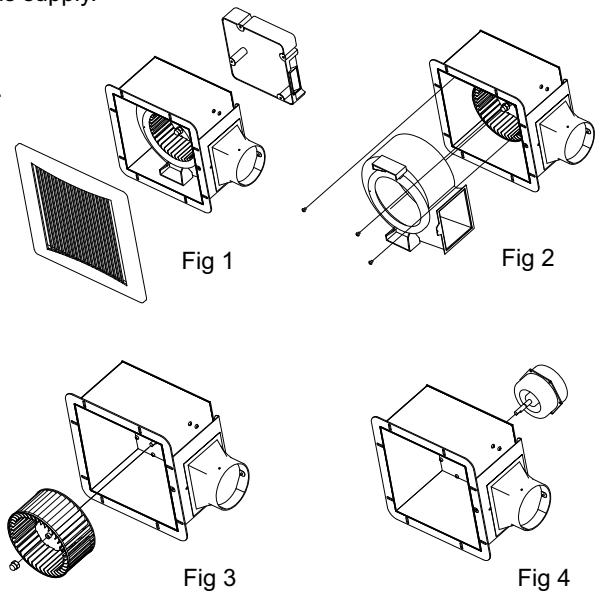

11. TROUBLESHOOTING TABLE

PROBLEM	POSSIBLE REASONS	TROUBLESHOOTING
<ul style="list-style-type: none"> • When switching on the unit the fan does not start. 	<ul style="list-style-type: none"> • No power supply. 	<ul style="list-style-type: none"> • Check the electrical connections and the power switch status.
	<ul style="list-style-type: none"> • Motor jamming. 	<ul style="list-style-type: none"> • Turn off the fan. • Troubleshoot the impeller jamming. • Restart the fan.
<ul style="list-style-type: none"> • Circuit breaker tripping during the fan start. 	<ul style="list-style-type: none"> • The automatic circuit breaker is triggered by an abnormally high current consumption due to a short circuit. 	<ul style="list-style-type: none"> • Disconnect the fan from power mains and contact the Breeze Seller. • Do not turn on the fan again.
<ul style="list-style-type: none"> • Low air flow. 	<ul style="list-style-type: none"> • Clogging of air ducts or other ventilation system elements. Impeller clogging. Damaged air ducts. Air damper closure. 	<ul style="list-style-type: none"> • Clean the air ducts and other ventilation system elements as well as the impeller. • Check the air ducts for damage. • Make sure the air dampers and louver shutters are open.
<ul style="list-style-type: none"> • Poor foundation 	<ul style="list-style-type: none"> • Excessive noise • Excessive vibration 	<ul style="list-style-type: none"> • Reinforce the foundation
<ul style="list-style-type: none"> • Fault installation 	<ul style="list-style-type: none"> • Excessive noise • Excessive vibration 	<ul style="list-style-type: none"> • Re-adjust the installation
<ul style="list-style-type: none"> • Low voltage 	<ul style="list-style-type: none"> • Insufficient air flow 	<ul style="list-style-type: none"> • Check power source
<ul style="list-style-type: none"> • Contact between rotary and stationary parts 	<ul style="list-style-type: none"> • Motor too hot • Excessive noise • Excessive vibration 	<ul style="list-style-type: none"> • Inspect and adjust
<ul style="list-style-type: none"> • Sucked in objects / Adhere dust 	<ul style="list-style-type: none"> • Motor too hot • Excessive noise • Excessive vibration 	<ul style="list-style-type: none"> • Inspect and clean
<ul style="list-style-type: none"> • Faulty ducting 	<ul style="list-style-type: none"> • Excessive noise • Excessive vibration • Insufficient air flow 	<ul style="list-style-type: none"> • Inspect and adjust
<ul style="list-style-type: none"> • Incorrect wiring 	<ul style="list-style-type: none"> • Run abnormally 	<ul style="list-style-type: none"> • Change wiring

12. TRANSPORT AND STORAGE

Transport

- Our products are packed at the factory to suit the respectively agreed mode of transportation. Transport the fan in its original packaging.
- Fans are protected against damage during shipment. If the unit cannot be installed and operated immediately, precautions need to be taken to prevent deterioration of the unit during storage. The user assumes responsibility of the fan and accessories while in storage. The manufacturer will not be responsible for damage during storage. These suggestions are provided solely as a convenience to the user.
- Only use suitable means of transport, such as pallet trucks or fork-lift trucks or hoist machine.
- If the fan is to be transported by hand, ensure that supporting and carrying loads are kept within reasonable limits for the personnel involved.
- The fans must not be dropped or thrown. Avoid scratches or rough handling during loading and unloading.
- Parts which have been stacked too high can collapse.
- Avoid a distortion of casing or blades or other damage.
- Danger ! Do not step under hanging loads.

Storage

- Store the unit in the manufacturer's original packaging box in a dry closed ventilated premise with temperature range from +5°C up to +40°C and relative humidity up to 85%.
- Store the fan in a dry, weather-protected location in its original packaging or protect it from the effects of dirt and the weather until final assembly. Storage environment must not contain aggressive vapours and chemical mixtures provoking corrosion, insulation and sealing deformation.
- Rotate fan impeller monthly and purge bearings once every three months.
- If storage of fan is in a humid, dusty or corrosive atmosphere, rotate the fan and purge the bearings once a month. Improper storage which results in damage to the fan will void the warranty.
- Avoid lengthy storage periods (a maximum of one year is recommended) and check that the motor bearing assembly is in good functional order prior to fitting. With storage times of more than 1 year, please check the bearings on soft running before installation (turn by hand).

Thank you for your cooperations!



Applied standard:



BREEZE INDUSTRIAL VENTILATION JOINT STOCK COMPANY

Vietnam

Head Office:

215D8 Nguyen Van Huong Street, Thao Dien Ward,
District 2, Ho Chi Minh City, Vietnam.

Tel: +84 28 6651 8585 | Hotline: +84 931 920 368

Factory:

12 Road No. 570, Xom Moi Hamlet, Trung Lap Ha
Commune, Cu Chi District, Ho Chi Minh City, Vietnam.

Tel: +84 28 6659 9589

Ha Noi Office:

55, Alley No. 14, Vu Huu Street, Thanh Xuan Bac Ward,
Thanh Xuan District, Ha Noi City, Vietnam.

Tel: +84 24 6683 8797 | Hotline: +84 906 568 557.

Website: www.breeze.com.vn

Email: breezefans@breeze.com.vn

Singapore

Office:

No 15, Yishun Industrial Street
1, #03-29, WIN5 Singapore
S768091.

Tel: +65-6254-2648

Myanmar

Office:

No.13/B, Kan Yeik Thar
Street, Thingangyun
Township, Yangon, Myanmar.